

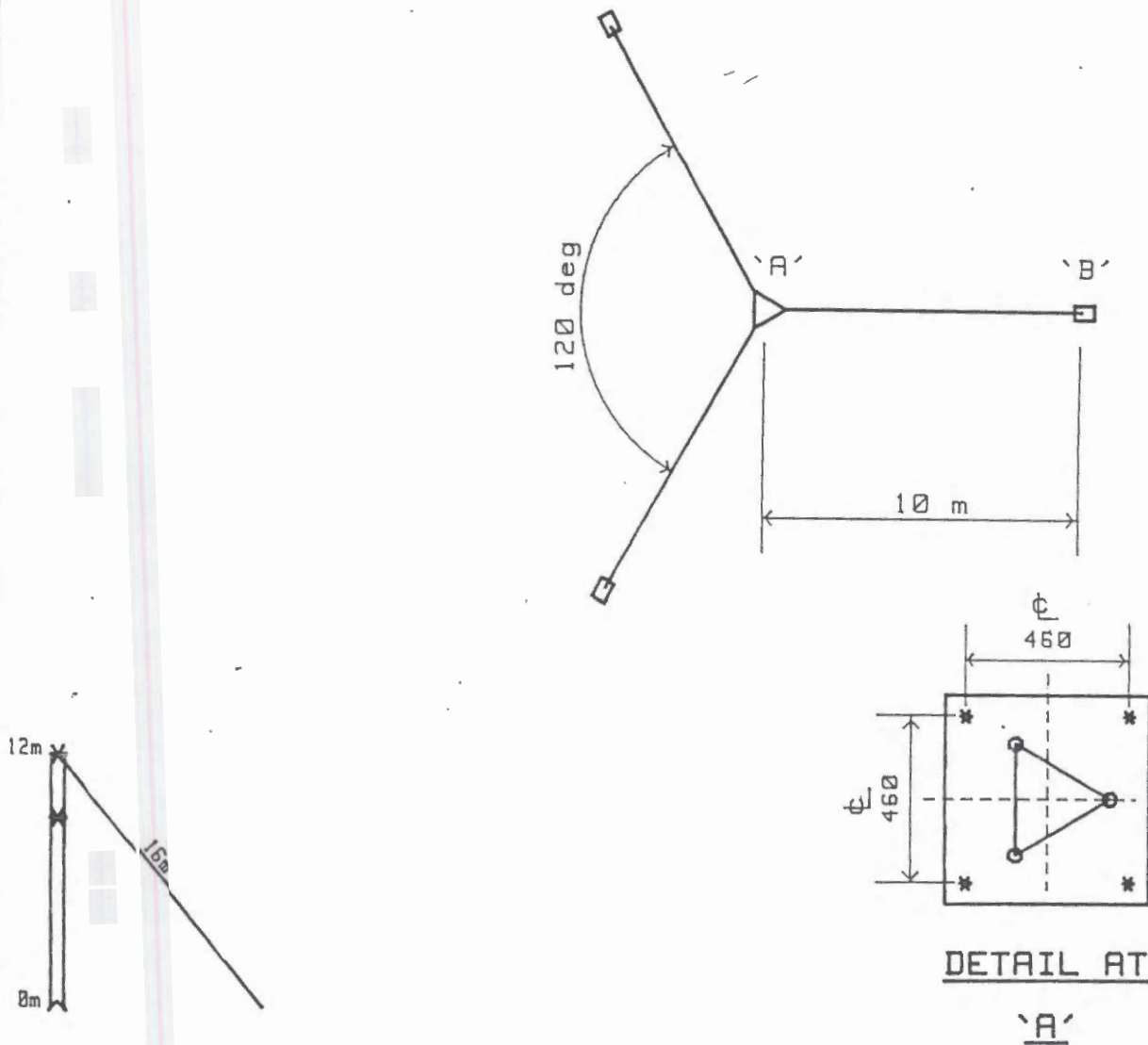

**ARRANGEMENT of 12 m GUYED LATTICE MAST**



**SPECIFICATION**

AERIAL/ANTENNA POSITION:- One at 12 m and One at 9 m  
 EACH ANTENNA:- AREA  $0.8m^2$ , HORIZONTAL LOAD 75 kg & MASS 60kg  
 GUY POST TENSIONING:-  
 6mm dia. 1.6kN ~ 8mm dia. 2.8kN ~ 9.8mm dia. 4.3kN  
 12mm dia. 6.5kN ~ 13.3mm dia. 7.7kN

**Designed by :- H. LAWRENCE & PARTNERS**

Consulting Engineers

Jan. 1989



**FOUNDATIONS for 12 m GUYED LATTICE MAST**

- a) VOLUME of CONCRETE REQ'D ~ 1.49 m<sup>3</sup>
- b) ANGLE of REPOSE of SOIL is 0 deg
- c) FOUNDATION BOLTS are M20 dia. @ 460mm CROSS CENTRES and PROJECT ABOVE THE CONCRETE 40mm.
- d) MASS of MAST 168 kg
- e) MASS of SUNDRIES 55 kg TOTAL MASS 231 kg
- e) MASS of GUYS 8 kg

DESCRIPTION	A	B	C	D	
VERTICAL LOAD	8.54	-3.18	0.00	0.00	kN
HORIZONTAL LOAD	1.01	2.91	0.00	0.00	kN
BENDING MOMENT	4.09				kNm
BEARING PRESSURE	50.58	162.45	0.00	0.00	kPa
FOUNDATION LENGTH	1.01	0.75	0.00	0.00	m
FOUNDATION L1	n/a	0.25	0.00	0.00	m
FOUNDATION L2	n/a	0.50	0.00	0.00	m
FOUNDATION WIDTH	1.01	0.65	0.00	0.00	m
FOUNDATION DEPTH	0.60	0.60	0.00	0.00	m
DEPTH BELOW G.L.	0.50	0.50	0.00	0.00	m

**BASE TYPE 'A'**

**BASES TYPE 'B', 'C' & 'D'**

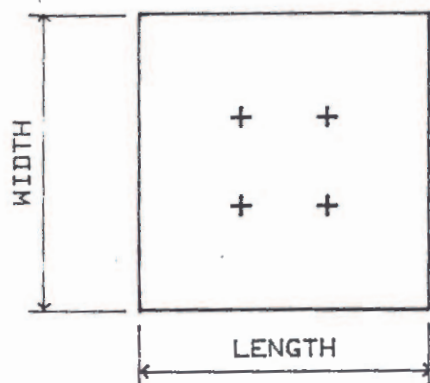

PLAN

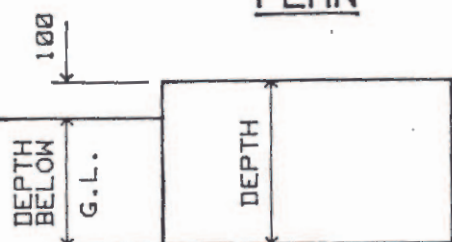

SECTION

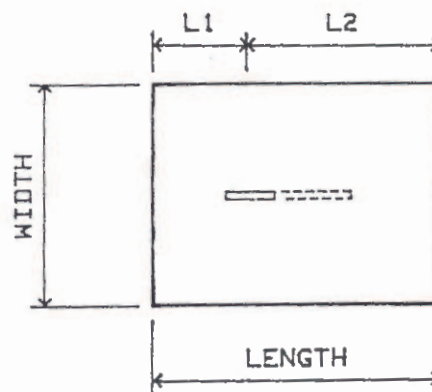

PLAN

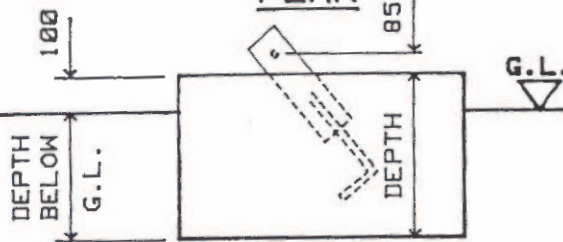

SECTION

Designed by :- H. LAWRENCE & PARTNERS

Consulting Engineers

Jan. 1989



**ARRANGEMENT of 18 m GUYED LATTICE MAST**

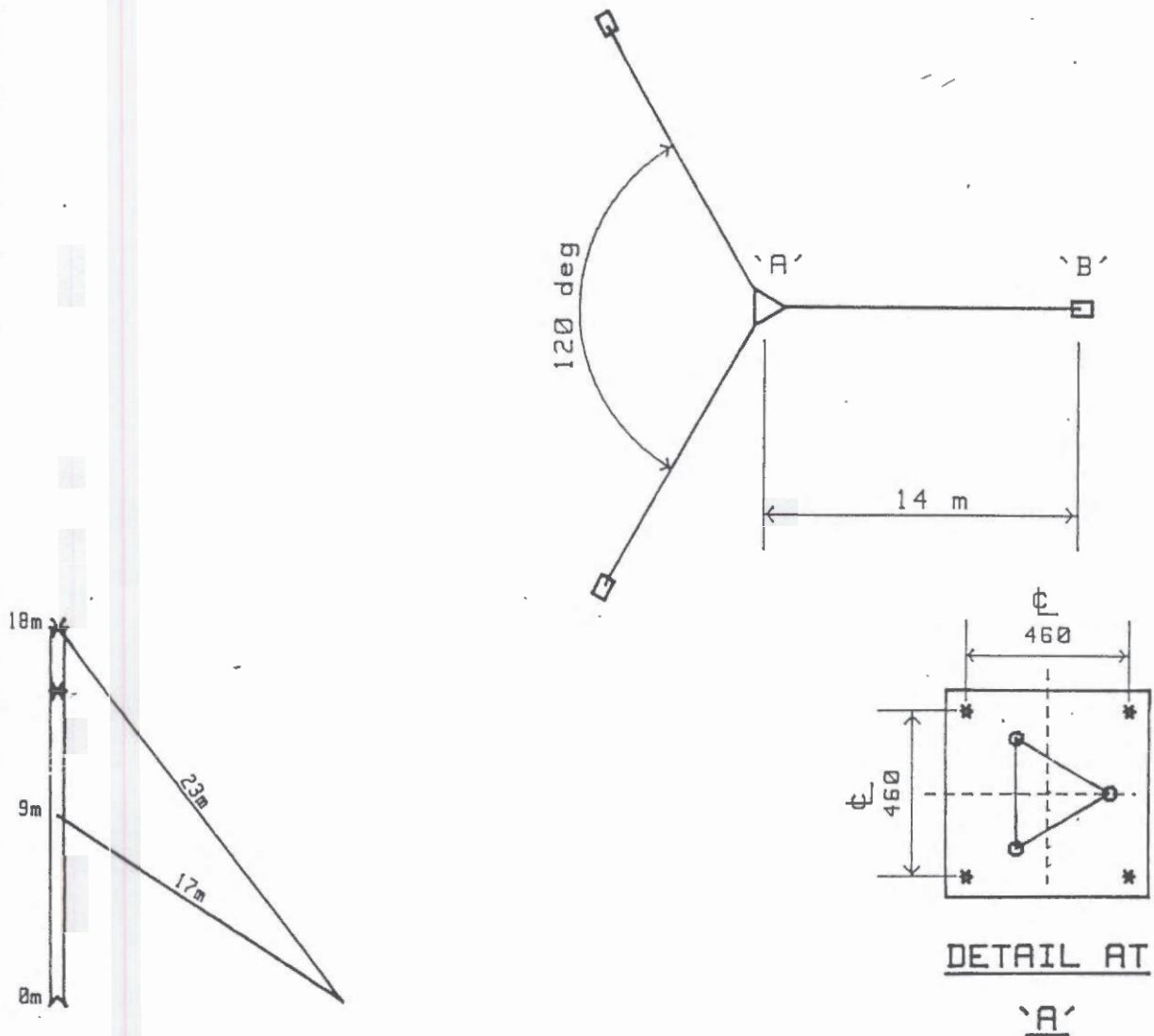

**SPECIFICATION**

AERIAL/ANTENNA POSITION:- One at 18 m and One at 15 m  
 EACH ANTENNA:- AREA  $0.8m^2$ , HORIZONTAL LOAD 86 kg & MASS 60kg  
 GUY POST TENSIONING:-  
 6mm dia. 1.6kN ~ 8mm dia. 2.8kN ~ 9.8mm dia. 4.3kN  
 12mm dia. 6.5kN ~ 13.3mm dia. 7.7kN

**Designed by :- H. LAWRENCE & PARTNERS**

Consulting Engineers

Jan. 1989



**FOUNDATIONS for 18 m GUYED LATTICE MAST**

- a) VOLUME of CONCRETE REQ'D ~ 1.77 m<sup>3</sup>
- b) ANGLE of REPOSE of SOIL is 0 deg
- c) FOUNDATION BOLTS are M20 dia. @ 460mm CROSS CENTRES and PROJECT ABOVE THE CONCRETE 40mm.
- d) MASS of MAST 252 kg
- e) MASS of SUNDRIES 55 kg TOTAL MASS 324 kg
- e) MASS of GUYS 17 kg

DESCRIPTION	A	B	C	D	
VERTICAL LOAD	13.63	-5.56	0.00	0.00	kN
HORIZONTAL LOAD	0.28	6.36	0.00	0.00	kN
BENDING MOMENT	1.41				kNm
BEARING PRESSURE	69.83	133.68	0.00	0.00	kPa
FOUNDATION LENGTH	0.70	1.00	0.00	0.00	m
FOUNDATION L1	n/a	0.33	0.00	0.00	m
FOUNDATION L2	n/a	0.67	0.00	0.00	m
FOUNDATION WIDTH	0.70	0.82	0.00	0.00	m
FOUNDATION DEPTH	0.60	0.60	0.10	0.10	m
DEPTH BELOW G.L.	0.50	0.50	0.00	0.00	m

**BASE TYPE 'A'**

**BASES TYPE 'B', 'C' & 'D'**

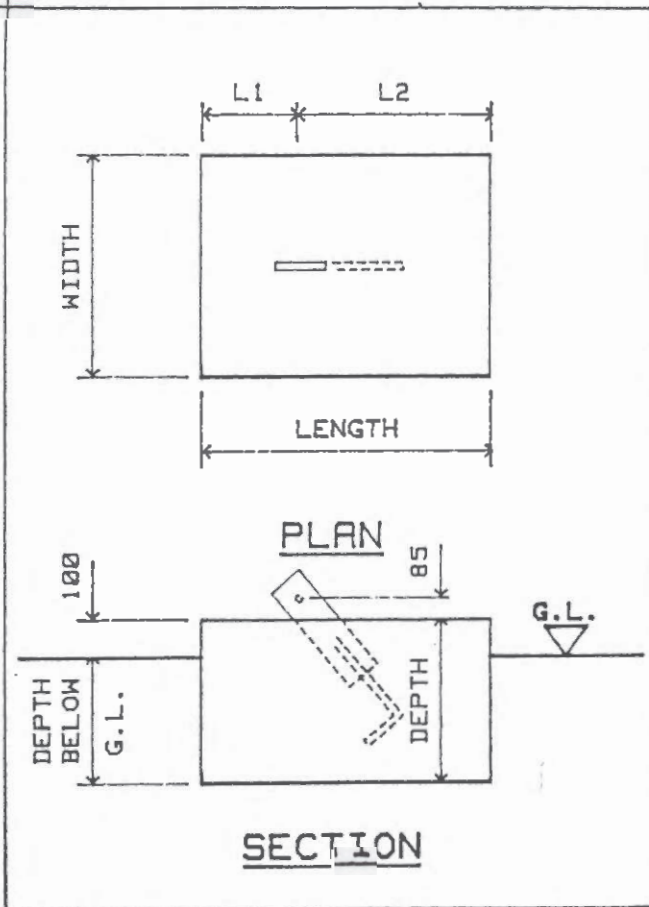
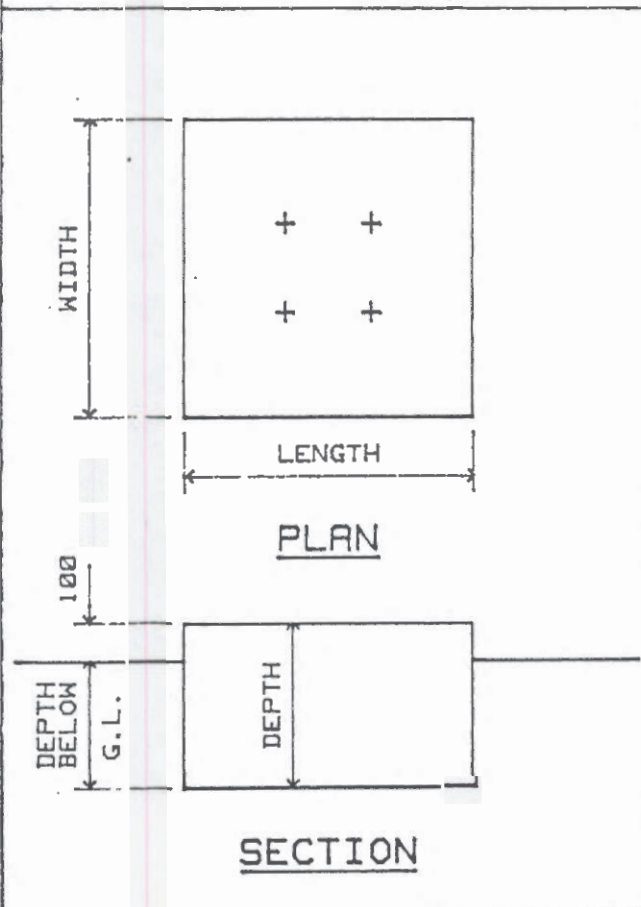

Designed by :- H. LAWRENCE & PARTNERS

Consulting Engineers

Jan. 1989



**ARRANGEMENT of 24 m GUYED LATTICE MAST**

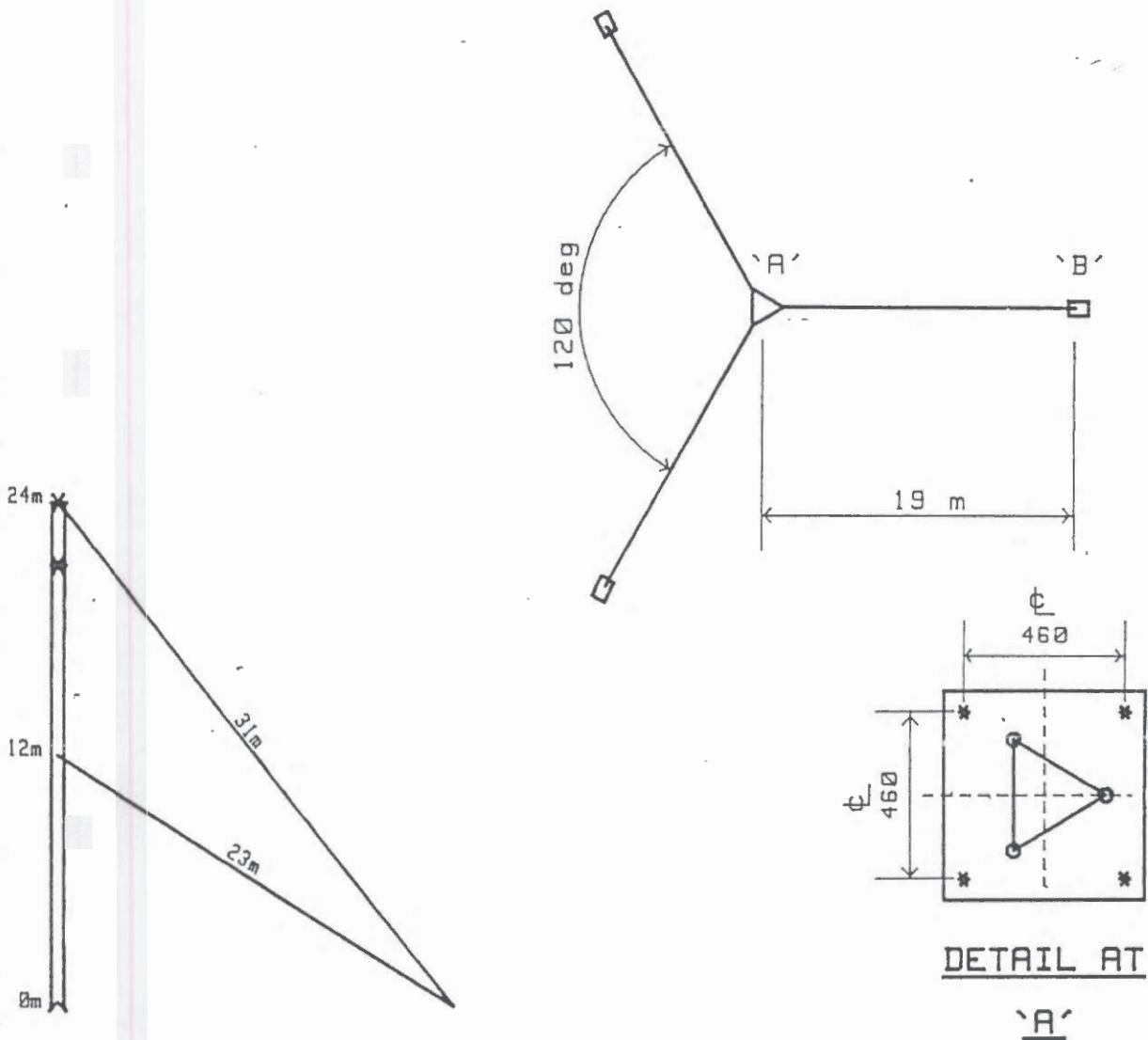

**SPECIFICATION**

AERIAL/ANTENNA POSITION:- One at 24 m and One at 21 m  
 EACH ANTENNA:- AREA  $0.8m^2$ , HORIZONTAL LOAD 92 kg & MASS 60kg  
 GUY POST TENSIONING:-  
 6mm dia. 1.6kN ~ 8mm dia. 2.8kN ~ 9.8mm dia. 4.3kN  
 12mm dia. 6.5kN ~ 13.3mm dia. 7.7kN

**Designed by :- H. LAWRENCE & PARTNERS**

Consulting Engineers

Jan. 1989



**FOUNDATIONS for 24 m GUYED LATTICE MAST**

- a) VOLUME of CONCRETE REQ'D ~ 1.95 m<sup>3</sup>
- b) ANGLE of REPOSE of SOIL is 0 deg
- c) FOUNDATION BOLTS are M20 dia. @ 460mm CROSS CENTRES and PROJECT ABOVE THE CONCRETE 40mm.
- d) MASS of MAST 336 kg
- e) MASS of SUNDRIES 55 kg TOTAL MASS 414 kg
- e) MASS of GUYS 23 kg

DESCRIPTION	A	B	C	D	
VERTICAL LOAD	15.27	-6.37	0.00	0.00	kN
HORIZONTAL LOAD	0.38	7.28	0.00	0.00	kN
BENDING MOMENT	1.62				kNm
BEARING PRESSURE	77.92	134.22	0.00	0.00	kPa
FOUNDATION LENGTH	0.70	1.03	0.00	0.00	m
FOUNDATION L1	n/a	0.34	0.00	0.00	m
FOUNDATION L2	n/a	0.68	0.00	0.00	m
FOUNDATION WIDTH	0.70	0.90	0.00	0.00	m
FOUNDATION DEPTH	0.60	0.60	0.10	0.10	m
DEPTH BELOW G.L.	0.50	0.50	0.00	0.00	m

**BASE TYPE 'A'**

**BASES TYPE 'B', 'C' & 'D'**

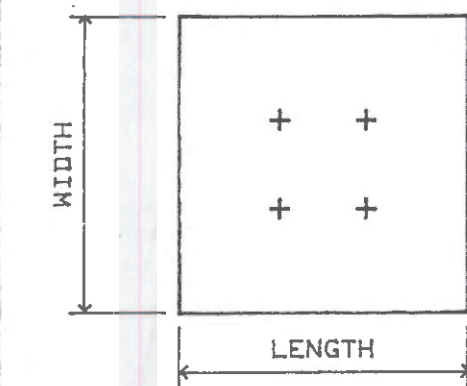

PLAN

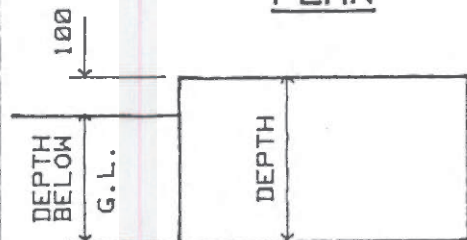

SECTION

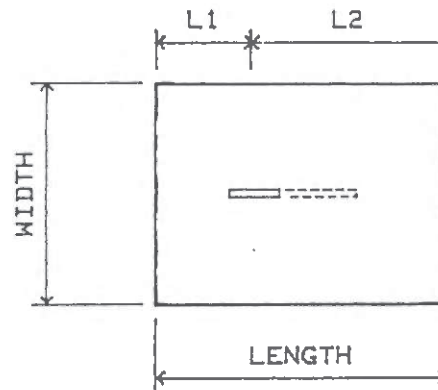

PLAN

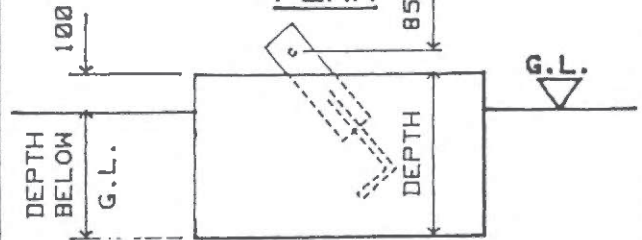

SECTION

Designed by :- H. LAWRENCE & PARTNERS

Consulting Engineers

Jan. 1989



**ARRANGEMENT of 30 m GUYED LATTICE MAST**

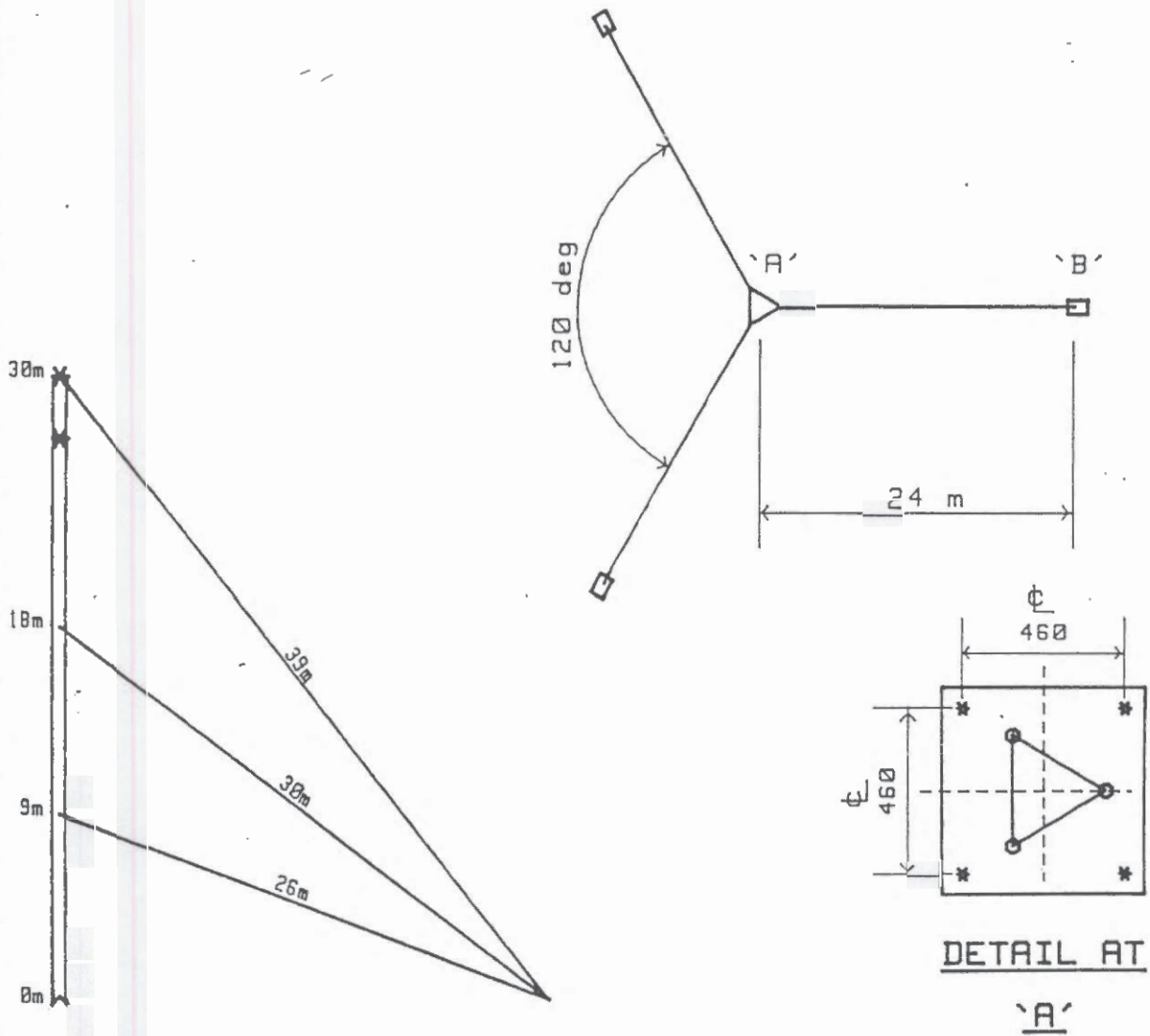

**SPECIFICATION**

AERIAL/ANTENNA POSITION:- One at 30 m and One at 27 m  
 EACH ANTENNA:- AREA  $0.8m^2$ , HORIZONTAL LOAD 97 kg & MASS 60kg  
 GUY POST TENSIONING:-  
 6mm dia. 1.6kN ~ 8mm dia. 2.8kN ~ 9.8mm dia. 4.3kN  
 12mm dia. 6.5kN ~ 13.3mm dia. 7.7kN

**Designed by :- H. LAWRENCE & PARTNERS**

Consulting Engineers

Jan. 1989

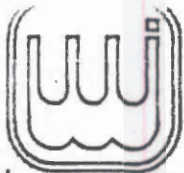

**FOUNDATIONS for 30 m GUYED LATTICE MAST**

- a) VOLUME of CONCRETE REQ'D ~ 2.35 m<sup>3</sup>
- b) ANGLE of REPOSE of SOIL is 0 deg
- c) FOUNDATION BOLTS are M20 dia. @ 460mm CROSS CENTRES and PROJECT ABOVE THE CONCRETE 40mm.
- d) MASS of MAST 420 kg
- e) MASS of SUNDRIES 55 kg TOTAL MASS 511 kg
- e) MASS of GUYS 36 kg

DESCRIPTION	A	B	C	D	
VERTICAL LOAD	19.18	-8.00	0.00	0.00	kN
HORIZONTAL LOAD	0.38	10.34	0.00	0.00	kN
BENDING MOMENT	1.34				kNm
BEARING PRESSURE	80.97	111.18	0.00	0.00	kPa
FOUNDATION LENGTH	0.70	1.20	0.00	0.00	m
FOUNDATION L1	n/a	0.40	0.00	0.00	m
FOUNDATION L2	n/a	0.80	0.00	0.00	m
FOUNDATION WIDTH	0.70	0.95	0.00	0.00	m
FOUNDATION DEPTH	0.60	0.60	0.10	0.10	m
DEPTH BELOW G.L.	0.50	0.50	0.00	0.00	m

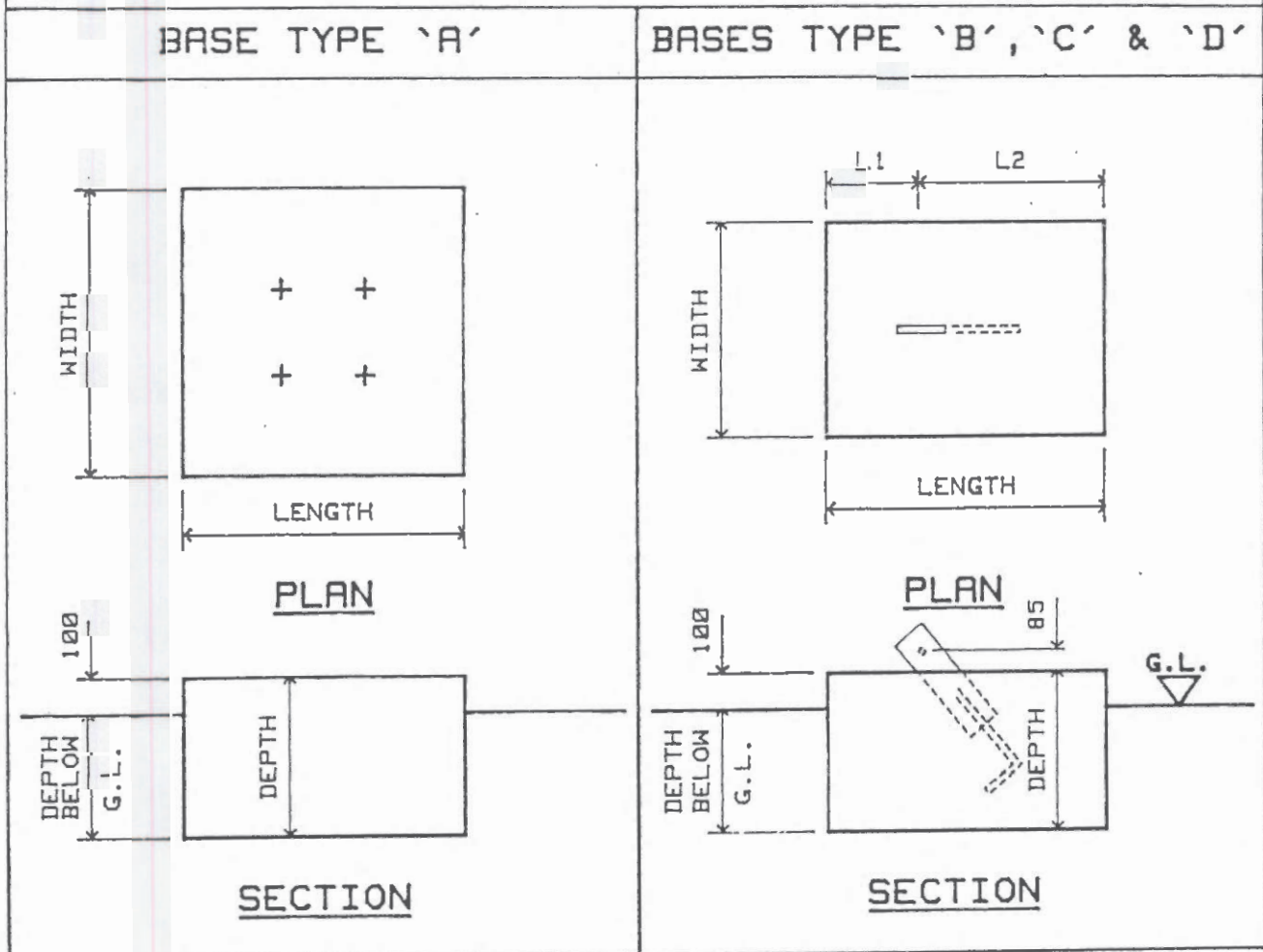

Designed by :- H. LAWRENCE & PARTNERS

Consulting Engineers

Jan. 1989





**ARRANGEMENT of 36 m GUYED LATTICE MAST**

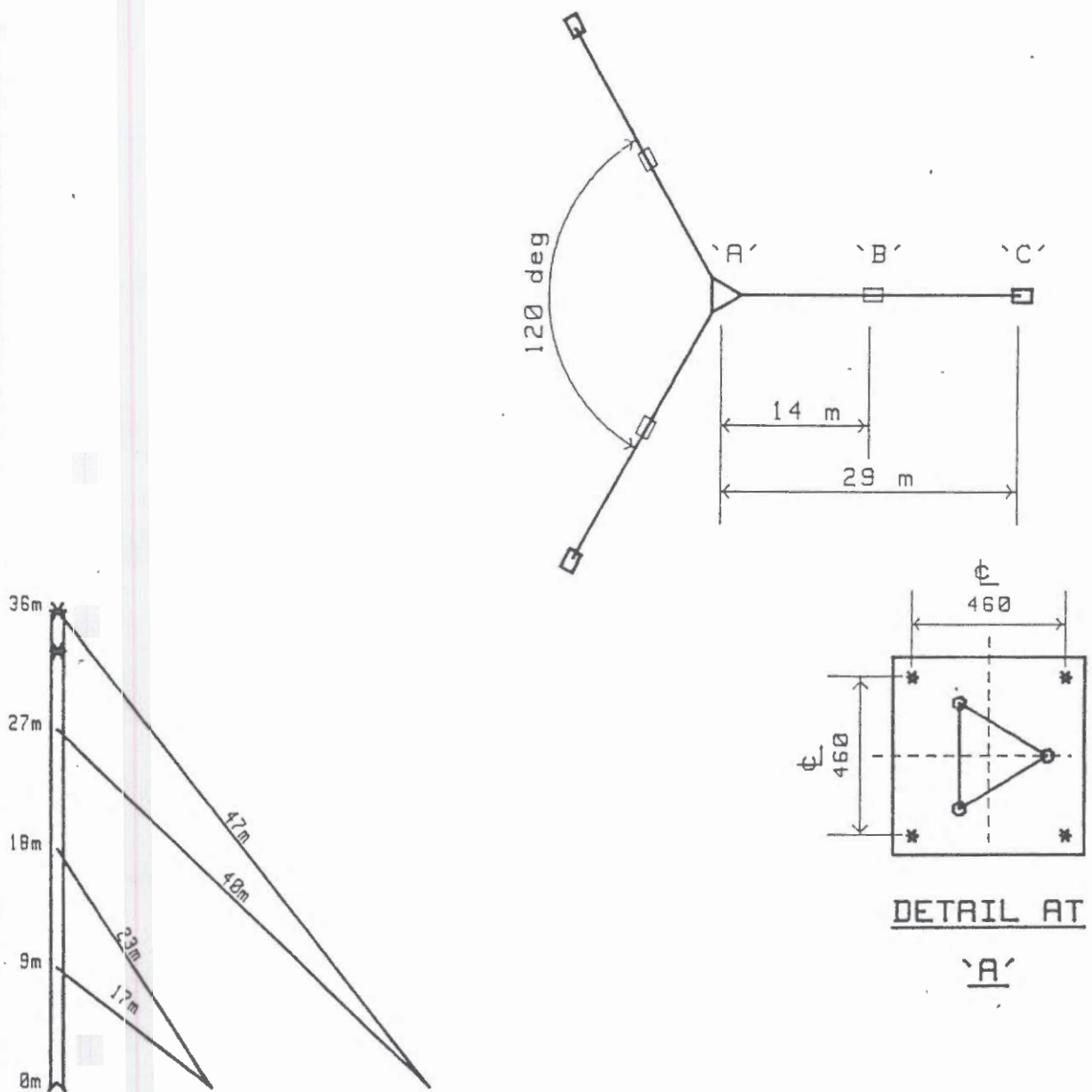

**SPECIFICATION**

AERIAL/ANTENNA POSITION:- One at 36 m and One at 33 m  
 EACH ANTENNA:- AREA  $0.8m^2$ , HORIZONTAL LOAD 102 kg & MASS 60kg  
 GUY POST TENSIONING:-  
 6mm dia. 1.6kN ~ 8mm dia. 2.8kN ~ 9.8mm dia. 4.3kN  
 12mm dia. 6.5kN ~ 13.3mm dia. 7.7kN

**Designed by :- H. LAWRENCE & PARTNERS**

Consulting Engineers

April 1990



**FOUNDATIONS for 36 m GUYED LATTICE MAST**

- a) VOLUME of CONCRETE REQ'D ~ 3.41 m<sup>3</sup>
- b) ANGLE of REPOSE of SOIL is 0 deg
- c) FOUNDATION BOLTS are M20 dia. @ 460mm CROSS CENTRES and PROJECT ABOVE THE CONCRETE 40mm.
- d) MASS of MAST 504 kg
- e) MASS of SUNDRIES 55 kg TOTAL MASS 615 kg
- e) MASS of GUYS 56 kg

DESCRIPTION	A	B	C	D	
VERTICAL LOAD	27.46	-4.17	-7.71	0.00	kN
HORIZONTAL LOAD	0.40	4.95	7.62	0.00	kN
BENDING MOMENT	1.41				kNm
BEARING PRESSURE	99.23	135.44	112.78	0.00	kPa
FOUNDATION LENGTH	0.70	0.95	1.18	0.00	m
FOUNDATION L1	n/a	0.32	0.39	0.00	m
FOUNDATION L2	n/a	0.63	0.79	0.00	m
FOUNDATION WIDTH	0.70	0.68	0.75	0.00	m
FOUNDATION DEPTH	0.60	0.65	0.70	0.00	m
DEPTH BELOW G.L.	0.50	0.55	0.60	0.00	m

**BASE TYPE 'A'**

**BASES TYPE 'B', 'C' & 'D'**

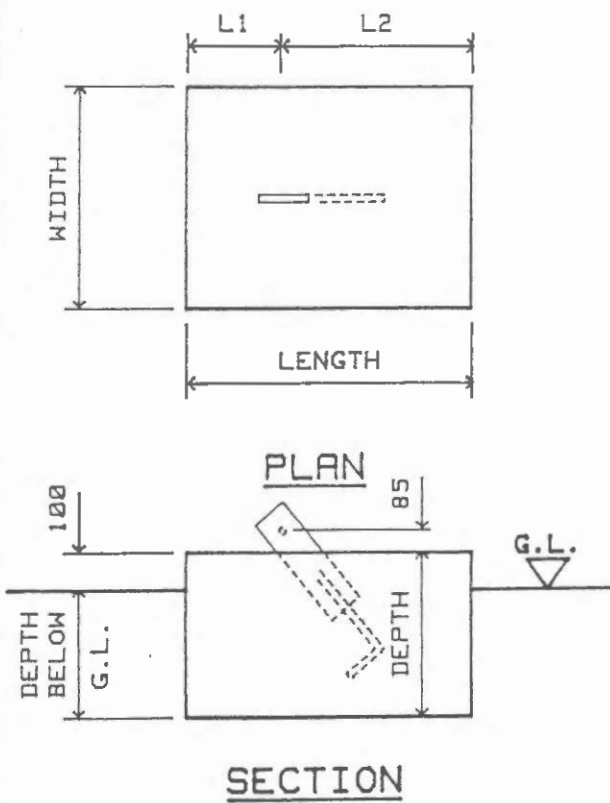
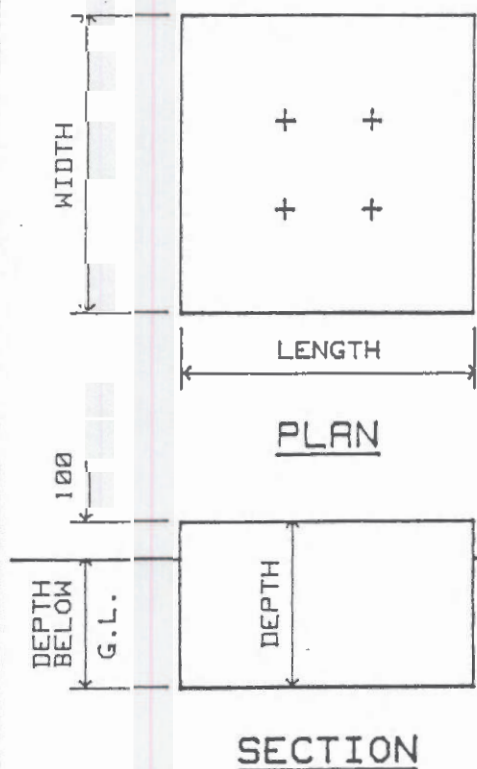

Designed by :- H. LAWRENCE & PARTNERS

Consulting Engineers

Jan. 1989